

Battery Backup Tech Tip

Introduction

Battery backup is required at many facilities to maintain protection of critical assets when power is lost. This document addresses the common questions and concerns regarding battery backup configuration.

Standard Battery Backup Requirements

When using the outdoor enclosure (P/N 980-43601) and battery backup (P/N 980-03608) configuration as-supplied by Fiber SenSys, a suitable battery backup is limited to a 10cm x 10cm x 20cm size constraint (approximately 4in x 4in x 8in) and must supply 12-24 VDC. The guidelines below can be used to determine the necessary capacity per site requirements.

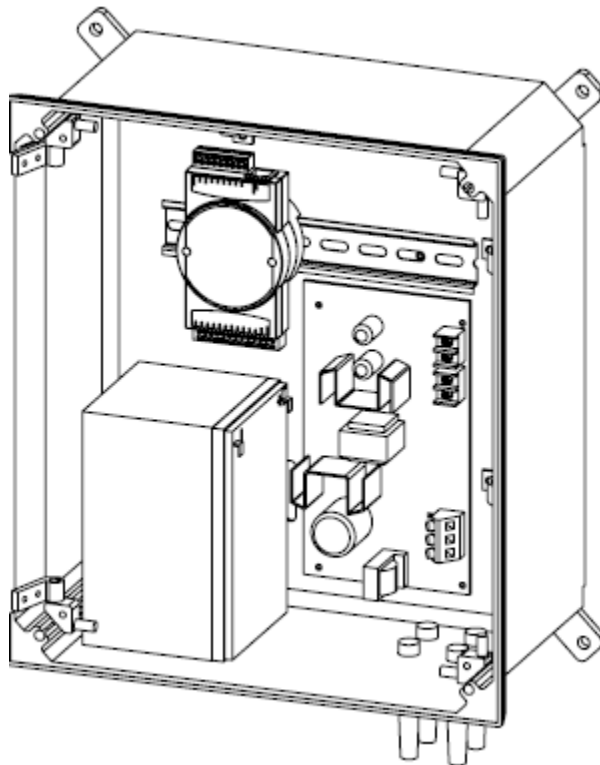

Figure 1 - Standard Outdoor Enclosure and Battery Backup Configuration

Determining Battery Backup Capacity

Battery backup capacity requirements vary from site to site. To determine a suitable battery backup for a specific application, follow the guidelines and example below.

Battery Backup Guidelines and Example:

1. Identify the required uptime as determined by the facility.
The system must operate for 12 hours on the backup battery.
2. Identify all hardware to be powered by the backup battery.

The system consists of an FD332 and ADAM I/O Module.

3. Identify maximum power consumption and voltage requirements of the hardware.

Equipment	Max Power	Voltage
FD332	4W	12-24 VDC
ADAM I/O	2W	10-30 VDC

4. Select an appropriate voltage to power the equipment.

12V is an appropriate voltage to power all the equipment.

5. Calculate the current for each piece of equipment using max power (W) and voltage (V).

$$\text{FD332 Current (A)} = 4\text{W} / 12\text{V} = .333\text{A}$$

$$\text{ADAM I/O Current (A)} = 2\text{W} / 12\text{V} = .167\text{A}$$

6. Calculate the required battery capacity in Amp Hours (AH) using the current (A) and uptime (hr).

$$\text{Battery Capacity (AH)} = (.333\text{A} + .167\text{A}) * 12\text{hr} = 6\text{AH}$$

A suitable backup battery in the scenario above would require 12V and a 6AH capacity.

Once voltage and capacity have been determined, space constraints and operating conditions (e.g., *significantly* reduced battery capacity in low temperatures) must be considered before an optimal backup battery can be selected.

Once a battery has been selected, it should be installed and tested for performance. It is also recommended that the battery backup continue to be tested periodically throughout the service life and be replaced as necessary per manufacturer's recommendations to ensure system performance.

Please contact Fiber SenSys technical support at +1 (503) 726-4455 or support@fibersensys.com for additional technical assistance.